

HITACHI HOIST

**HITACHI EXPLOSION-PROOF
HOIST/CRANE SADDLE**

HITACHI
Inspire the Next



Sufficient consideration is given to the safety and reliability, since it is used in a site using an explosive gas.

Explosion-proof Hoist

Features

The Hitachi explosion-proof hoist is a rational system consisting of functional units of brake, motor, drum and emergency brake.

It uses a brake with automatic adjusting device developed by Hitachi for the first time in the world, saving the time and labor on the troublesome brake adjustment, as well as facilitating the maintenance.

If, by any chance, the main brake does not function suffi-

ciently, a new type emergency brake having a small shock prevents the load from dropping down, forming a double-brake mechanism combined with the brake with automatic adjusting device.

- When the load block is hoisted up to its upper limit, the operating circuit of electromagnetic switch is cut-off, interrupting the load block operation. Even if the operating circuit is shorted and the load block continues to rise, the safety is secured because of the "double-limit system" that cuts off the main circuit for the motor.

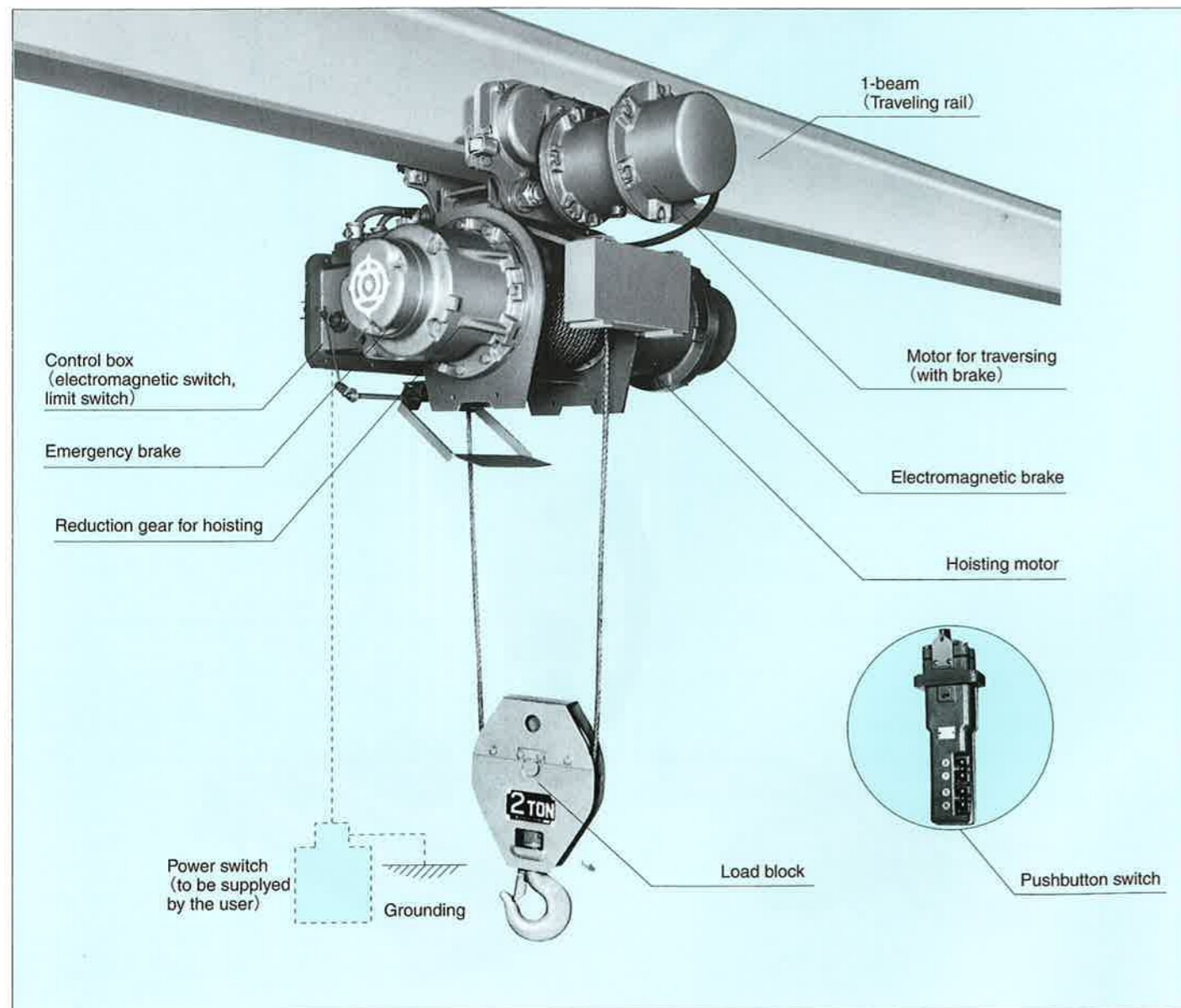

The Hitachi explosion-proof hoist/crane saddle is designed for operation in a chemical or coating plant using an explosive gas.

The explosion-proof ability of the hoist/crane saddle is applicable to a range of gas up to Ignition group G4 and Explosion class 2. (Refer to the Table of Explosion and Ignition Ratings for Explosive Gases, provided on Page 15.)

- The electric-system of Hitachi explosion-proof hoist/crane saddle is totally enclosed. Even if an explosive gas exploded within the container, the container withstands the pressure of such an explosion and the gas existing out-

side of the container is not ignited, guaranteeing the explosion proof of the hoist/crane saddle.

- The explosion-proof ability of the hoist/crane saddle is determined by the stipulations of either the "Explosion-proof Guideline for Electrical Equipment in Factories" or "Explosion-proof Standard for Gases and Vapor" though the conditions vary by the ignition group and explosion class of the using gas and the place of its existence.

Not only the motor, but the brake and terminal box are all given the explosion-proof treatment. (Product approved by the Ministry of Labor)

Explosion-Proof Crane Saddle

Features

- The brake torque adjustment range is as wide as 0 to 60% of the rated motor torque, facilitating the adjustment work.
- The centering mark for crane assembling adjustment helps substantially reducing the working time.

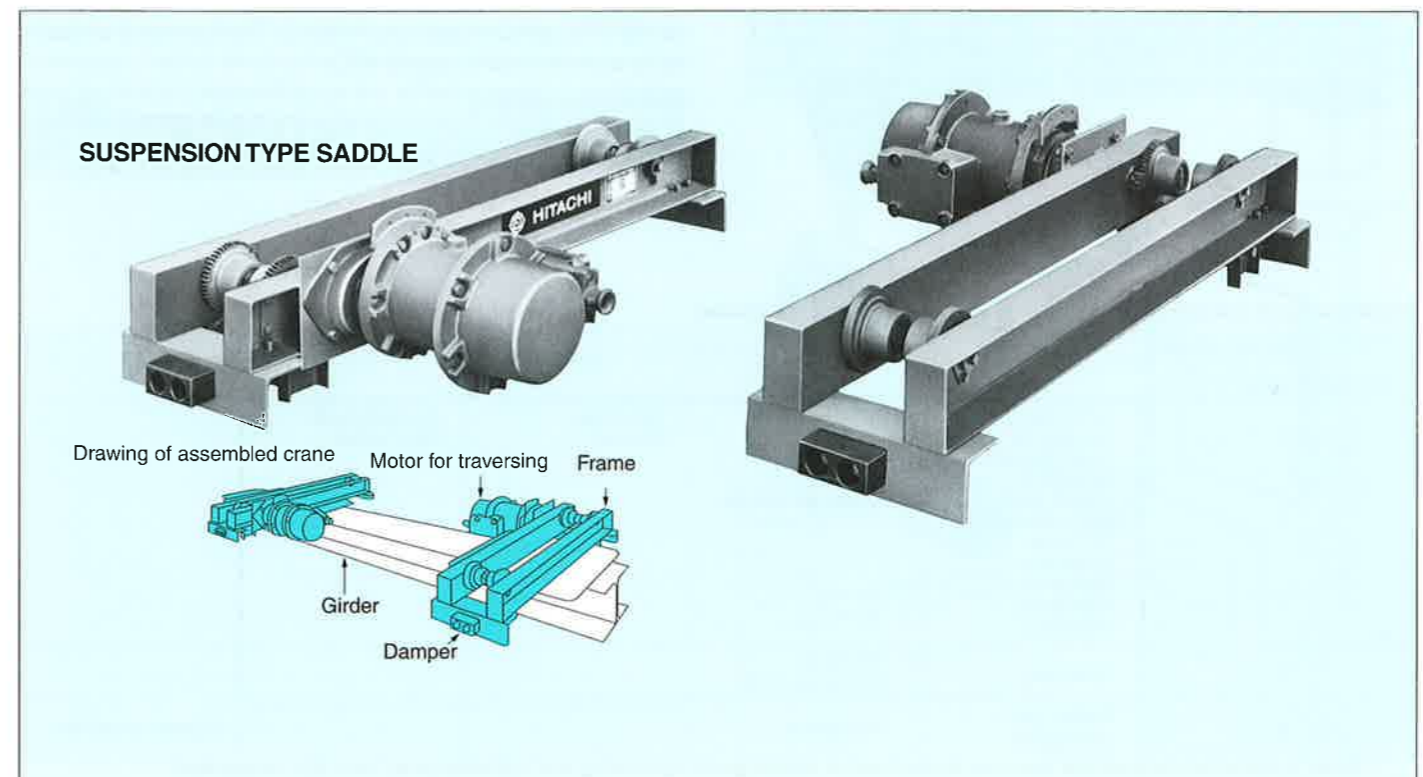

BASIC SPECIFICATIONS

Hitachi's explosion-proof hoist is designed so that it corresponds to the following regulation categories of the Japanese Ministry of Labor.

- Construction Pressre Proof d
- Ignition group G1-G4
- Explosion class 1,2
- Division of hazardous locations .. 2

In order for this explosion-proof hoist to be operated safely even places with explosive gas, its explosion-proof construction should always be effective so reasonable care should be taken in its maintenance. Also, any building in which the explosion-proof hoist is to be installed should be equipped with a dependable ventilation system so that explosive gas can be eliminated effectively.

The standard ambient conditions for explosion-proof electrical equipment are as follows:

Altitude	Up to 1,000m
Ambient temperature	-10~+40°C
Relative humidity	45~85%

CLASSIFICATION OF EXPLOSIVE GASES

Explosive gases are classified according to their ignition rating and explosive rating which vary respectively depending on the degree of danger.

(1) Ignition group

Ignition groups are classified as follows according to the ignition Points of the individual gases. The Hitachi explosion-proof hoist can be used for gases of up to G4 for ignition groups or up to 135°C for ignition point.

Ignition group G ₁ : Ignition point	Over 450°C
Ignition group G ₂ : Ignition point	Over 300°C -- Under 450°C
Ignition group G ₃ : Ignition point	Over 200°C -- Under 300°C
Ignition group G ₄ : Ignition point	Over 135°C -- Under 200°C
Ignition group G ₅ : Ignition point	Over 100°C -- Under 135°C
Ignition group G ₆ : Ignition point	Over 85°C -- Under 100°C

Classification of explosive gases by ignition groups and explosion classes

Ignition group	G1	G2	G3	G4	G5
Explosion class					
1	Acetone Ammonia Carbon monoxide Ethane Acetic acid Ethyl acetate Toluene Propane Benzene Methanol Methane	Ethanol Isomyl acetate Butanol Butane Acetic anhydride	Gasoline Hexane	Acetaldehyde Ethyl ether	
2	Coal gas	Ethylene Ethylene oxide			
3	Water gas Hydrogen	Acetylene			Carbon disulfide

*Gases listed within the bold line frame are those in which Hitachi pressure-resisting and explosion-proof hoist can be operated.

NAMING AND TYPE OF EXPLOSION-PROOF HOIST

As for the naming and indication of type, the indication of "explosion-proof" comes first, and "-XX" for the indication of the type follows the term.

(Example) Explosion-proof Type Hoist: 1HM-T55-XX

In requesting an estimate of cost or placing an order for the explosion-proof hoist, information concerning the following should be indicated in detail.

- Kind of gas.
- Concentration of gas.
- Ventilation condions of the room where the gas exists.
- Working conditions (including frequency of hoist use).
- Whether electromagnetic switches or push buttons are installed in the room where the gas exists or whether there is separate room that is free of the effect of the gas.
- Distance of traversing travel (Also, indicate if any curved travel is included)

* Constructions of other electrical equipment installed in the room where the gas exists (Indicate whether they are explosion-proof types or not).

(2) Explosion class

Explosion class is classified into the following depending on the value of the gap through which the ignition spreads.

Explosion class 1:	Value of gap Over 0.6 mm
Explosion class 2:	Value of gap Over 0.4 mm Under 0.6 mm
Explosion class 3:	Value of gap Under 0.4 mm

(3) Classification of explosive gases

Typical explosive gases classified by their ignition and explosion ratings are as follows:

(4) Upper limit of temperature rise

The upper limit of temperature rise of electrical equipment using an explosive gas is as follows. The standard ambient temperature in this case is 40°C.

Temperature rise limit	(unit: °C)					
	G ₁	G ₂	G ₃	G ₄	G ₅	G ₆
Upper limit of temperature rise	320	200	120	70	40	30

Classification of Hazardous Locations

Hazardous locations are classified into three divisions of 0-location, 1-location and 2-location by the frequency and time of an explosive atmosphere being generated. This classification is provided to ensure taking technical measures that are optimum to the whole plant by selecting suitable explosion-proof electrical equipment and wiring to each hazardous location according to the degree of danger.

(Remarks: A hazardous location must be determined three-dimensionally rather than as a plane.)

(1) Division 0

A location of Division 0 is defined as a place where an explosive atmosphere is generated continuously or for a long time in the normal operation state.

(2) Division 1

A location of Division 1 location is defined as a place where an explosive atmosphere may be generated cyclically or occasionally in the normal operation state.

(3) Division 2

A location of Division 2 location is defined as a place where an explosive atmosphere may be generated in an irregular state.

Explanation

- 1 The "long time" referred to in the Division 0 clause means two cases of a long time as the phrase means literally and a case in which the generation is short but repeated often during a long period of time.
- 2 The "irregular state" referred to the Division 2 clause does not include such a case that is outside of the range of explosion-proof of electrical equipment in a plant because of an earthquake or other accident exceeding normal anticipation.

A hazardous location must be determined based on the expansion of space, quantity of hazardous material, types of equipment and work, effectiveness of ventilation, existence of hazard prevention device in the place and in full reviews of explosion or a fire in the same type enterprise. The degree of danger may be lowered or the range of hazardous location may be limited depending on the effectiveness of ventilating or airing equipment.

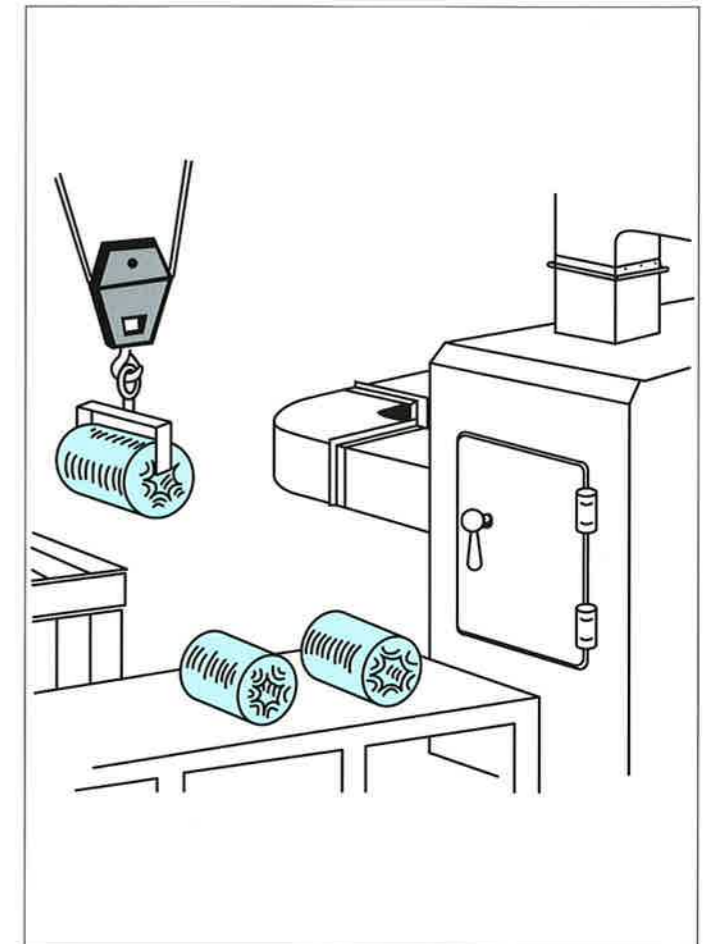
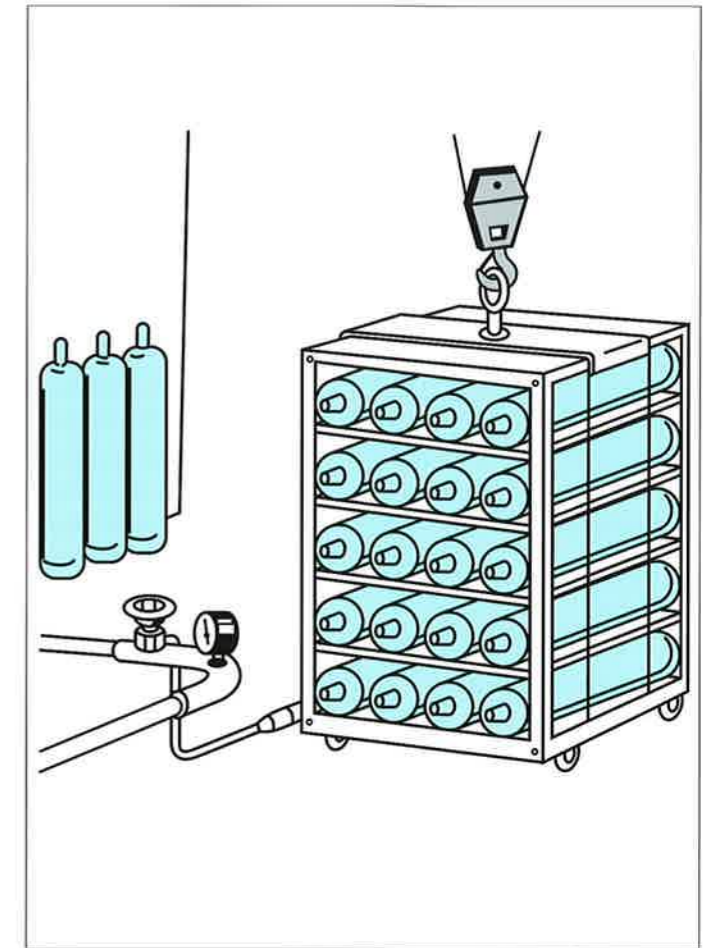

Explosion-Proof Hoist

Standard Specifications

Power supply	3-phase 200V 50/60Hz, 220V 60Hz (380V~400V, 415V 50Hz, 400~440V 60Hz are available)
Operation method	Operating pushbuttons 2-point pushbuttons (UP and DOWN in the drawing) for suspension type stationary type, push-driven traversing type, and chain-driven traversing type 4-point pushbuttons (UP, DOWN, LEFT and RIGHT in the drawing) for electric motor-driven traversing type
Rating	Duty rating 40% ED, Number of starting 250 starts/hr (up to 3 t) (Duty rating 25% ED, Number of starting 250 starts/hr for 5 t)
Power feed method	By power cable (cable and fixing metal pieces are not attached.) Use 3PNCT to supply the power to explosion-proof hoist. The standard cable size is 4C×3.5mm ² (finished outer diameter φ19.1) for up to 2 t or 4C×8mm ² (finished outer diameter φ22.3) for 3 and 5 t. Specify separately if the cable size is different.
Explosion-proof structure	Explosion-proof type d2G4 Indoor use only
Applicable standards	JIS C9620 Electric hoist, Crane structure standards, Safety Regulations of Crane and Others, Explosion-proof Guideline for Electrical Equipment in Factories

System diagram of explosion-proof type hoist crane

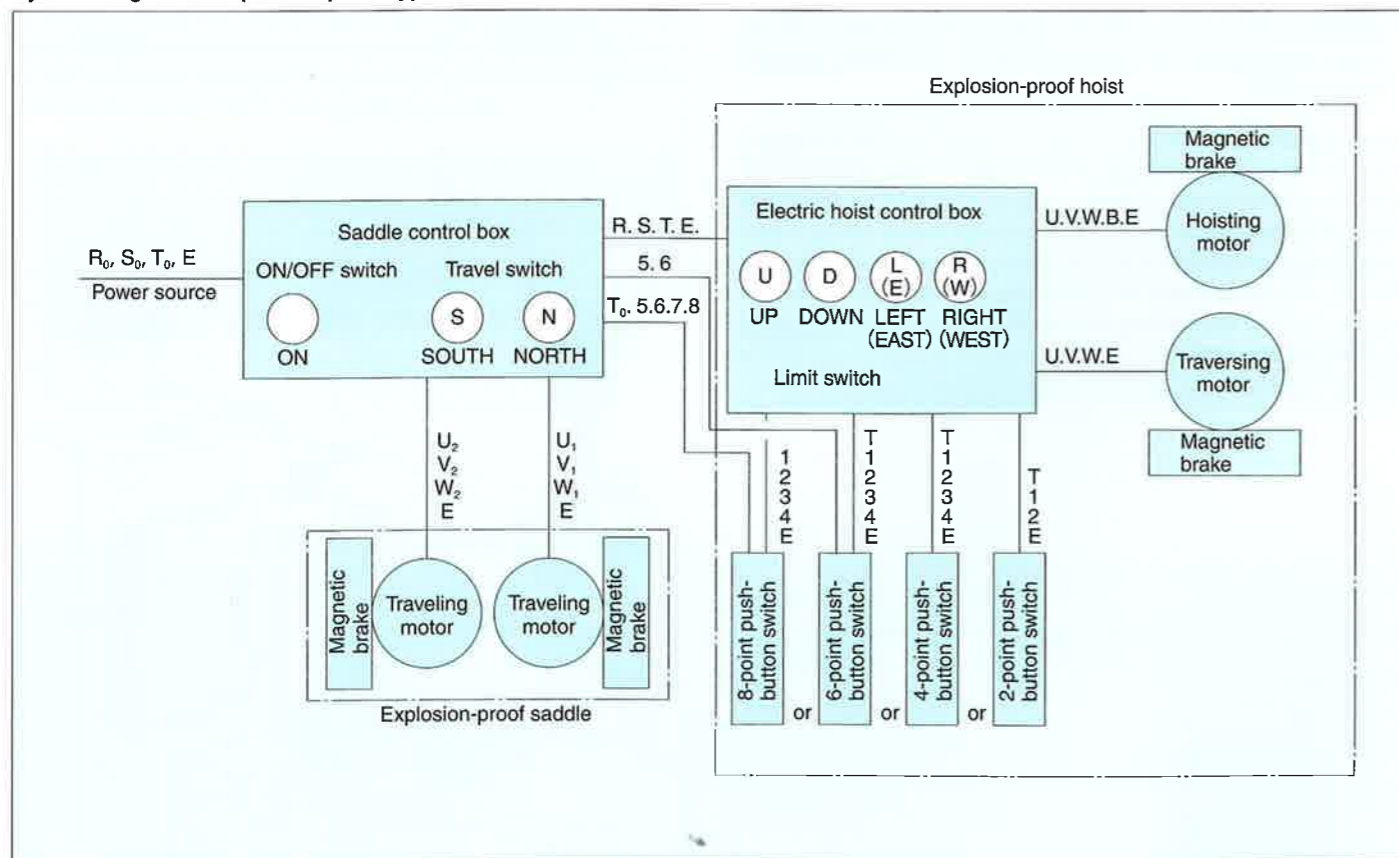

Note) A connecting cable from the pushbutton switch to the saddle control box is needed in the case of 6-point or 8-point push-button switch. Specify the length taking the maximum distance from the hoist to the saddle control box mounting position. (The connecting cable must be estimated separately.)

When purchasing a cable locally, make sure to purchase a length taking the length from the pushbutton switch to the hoist into consideration. Use the 3PNCT cable of 2C×2mm² (finished outer diameter φ15.2) for 6-point switch or 5C×2mm² (finished outer diameter φ18.6) for 8-point switch.

TABLE OF SPECIFICATIONS

Type	Standard head room type				Low head room type				Double-rail type				
	1	2	3	5	1	2	3	5	2	3	5		
Capacity (ton)	1	2	3	5	1	2	3	5	2	3	5		
Hoisting lift (m)	6,12,24,36			8,12 *24,36	6,12			6,11	12	6,12	8,12		
Hoisting	Speed (m/min)	50 Hz	11	8.4	7.5	6.7	11	8.4	7.5	6.7	8.4	7.5	6.7
		60 Hz	13	10	9	8	13	10	9	8	10	9	8
Motor (kW)		50 Hz	1.9	2.9	4.2	5.9	1.9	2.9	4.2	5.9	2.9	4.2	5.9
		60 Hz	2.3	3.5	5.0	7.0	2.3	3.5	5.0	7.0	3.5	5.0	7.0
Traveling	Speed (m/min)	50 Hz	21										
		60 Hz	25										
Motor (kW)		50 Hz	*0.30 *0.30×2	*0.63 *0.30×2	*0.63 *0.63×2	0.30	0.63	0.30	0.63	0.30	0.63		
		60 Hz	*0.36 *0.36×2	*0.75 *0.36×2	*0.75 *0.75×2	0.36	0.75	0.36	0.75	0.36	0.75		
Wire rope	Number of fall	2			4 *2	4							
	Composition	6×Fi(29) —B *4×F(40) —B		6×Fi(29) —B *6×37 —A	6×W (19) —B	6×Fi(29) —B							
	Diameter (mm)	φ 8	φ 11.2	φ 14	φ 12.5 *φ 18	φ 6.3	φ 8	φ 10	φ 12.5	φ 8	φ 10	φ 12.5	
Rating	Duty Rating	40% (25% for 5 t)											
	Starting rate	250 times/hour											
Power source	Main circuit	200V 50/60Hz, 220V 60Hz (380V~400V, 415V 50Hz, 400V~440V 60Hz are available)											
	Operating circuit	200V 50/60Hz, 220V 60Hz (100V is available)											
Operating method	Operating push-button												

- Note) 1. Low speed (half of the standard speed) for hoisting and/or traversing is available, on order.
2. We can accept a request for the capacity of 1/2 t, 2.8 t, 7.5 t and 10 t.
3. *The number of falls for 24m and 36m of the suspension type is 2, and the wire rope diameter is φ 18.

Standard Head room Type

Hoist with Motorized Trolley

Dimensional diagram

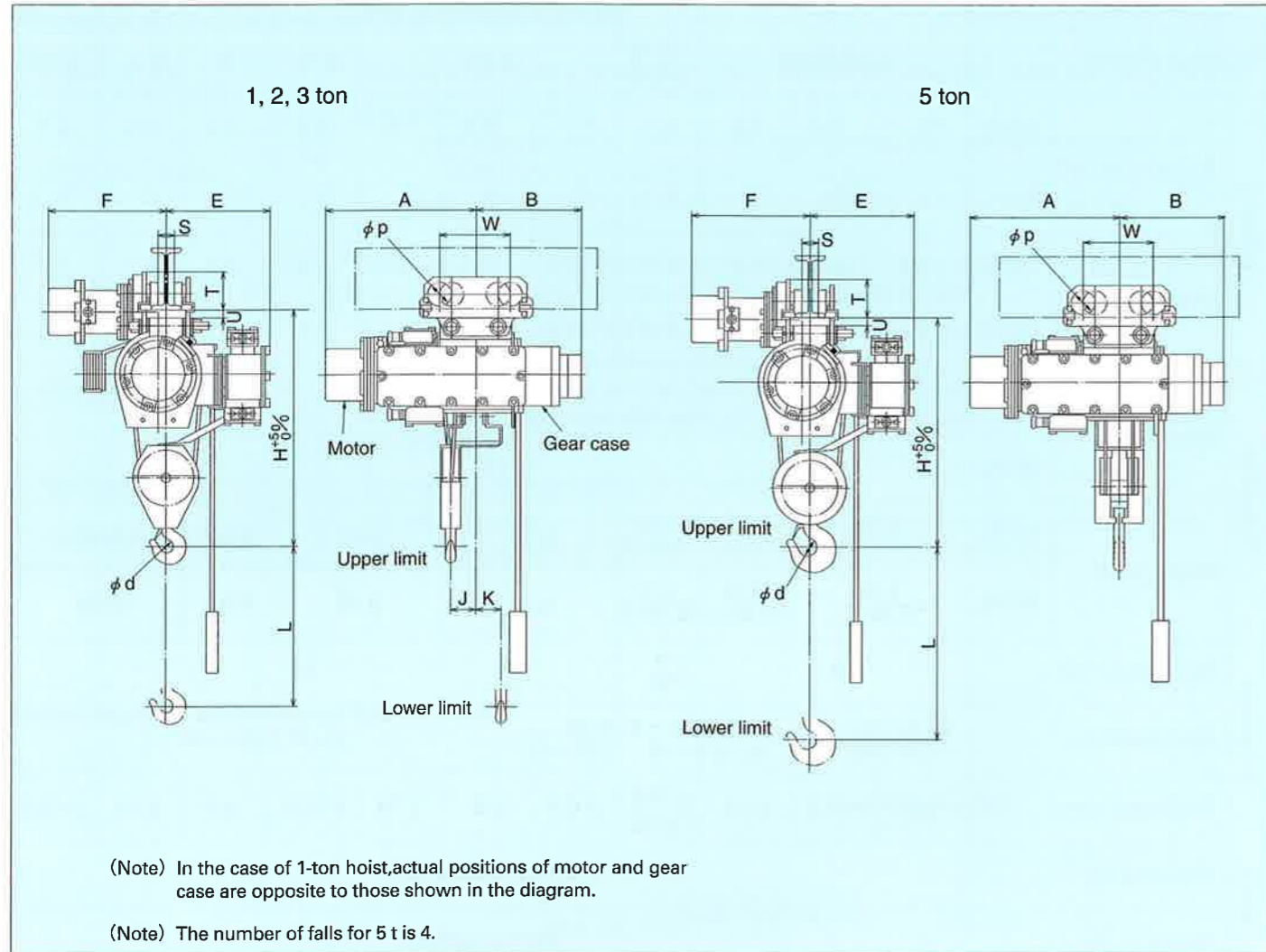

Capacity (ton)		1		2		3		5																																			
Type	1M-T ₆₅ -XX	1HM-T ₆₅ -XX	2M-T ₇₅ -XX	2HM-T ₇₅ -XX	3M-T ₆₅ -XX	3HM-T ₆₅ -XX	5M-T ₆₅ -XX	5HM-T ₆₅ -XX																																			
Approx. dimensions (mm)	L	6,000	12,000	6,000	12,000	6,000	12,000	8,000	12,000																																		
	H	790		985		1,115		1,190																																			
	A	570	740	625	660	690	730	890	1,000																																		
	B	475	510	435	615	475	660	690	800																																		
	J	85	115	75	100	80	110	—	—																																		
	K	20	90	30	110	35	120	—	—																																		
	φd	45		56		71		90																																			
	φp	96		96		128		156/140 Drive side/Following side																																			
	W	200/290		200/290		230/310		250/330																																			
	Min. curve radius (m)	1.8		2.0		2.5		3.5																																			
Dimensions of I-beam (mm)	E	F	S	T	U	E	F	S	T	U	E	F	S	T	U	E	F	S	T	U																							
200×100×7	430	467	42	148	47	490	467	42	148	42	—	—	—	—	—	—	—	—	—	—	—	—	—	—	—	—	—	—	—	—	—	—	—	—	—	—	—	—	—	—	—	—	—
250×125×7.5	430	480	67	151	44	490	480	67	151	39	530	480	52	177	38	—	—	—	—	—	—	—	—	—	—	—	—	—	—	—	—	—	—	—	—	—	—	—	—	—	—		
300×150×11.5	430	493	92	160	35	490	493	92	160	29	530	493	77	187	28	540	510	77	225	30	—	—	—	—	—	—	—	—	—	—	—	—	—	—	—	—	—	—	—	—	—	—	
450×175×11	—	—	—	—	—	—	—	—	—	—	530	506	102	185	30	540	523	102	223	32	—	—	—	—	—	—	—	—	—	—	—	—	—	—	—	—	—	—	—	—	—		
Approx. weight (kg)	325		340		430		450		545		585		840		910																												

(Note) Unless otherwise specified, trolley is being assembled so as to meet smudged I-beam.

Standard Head room Type

Hoist with Chain-Driven Trolley

Dimensional diagram

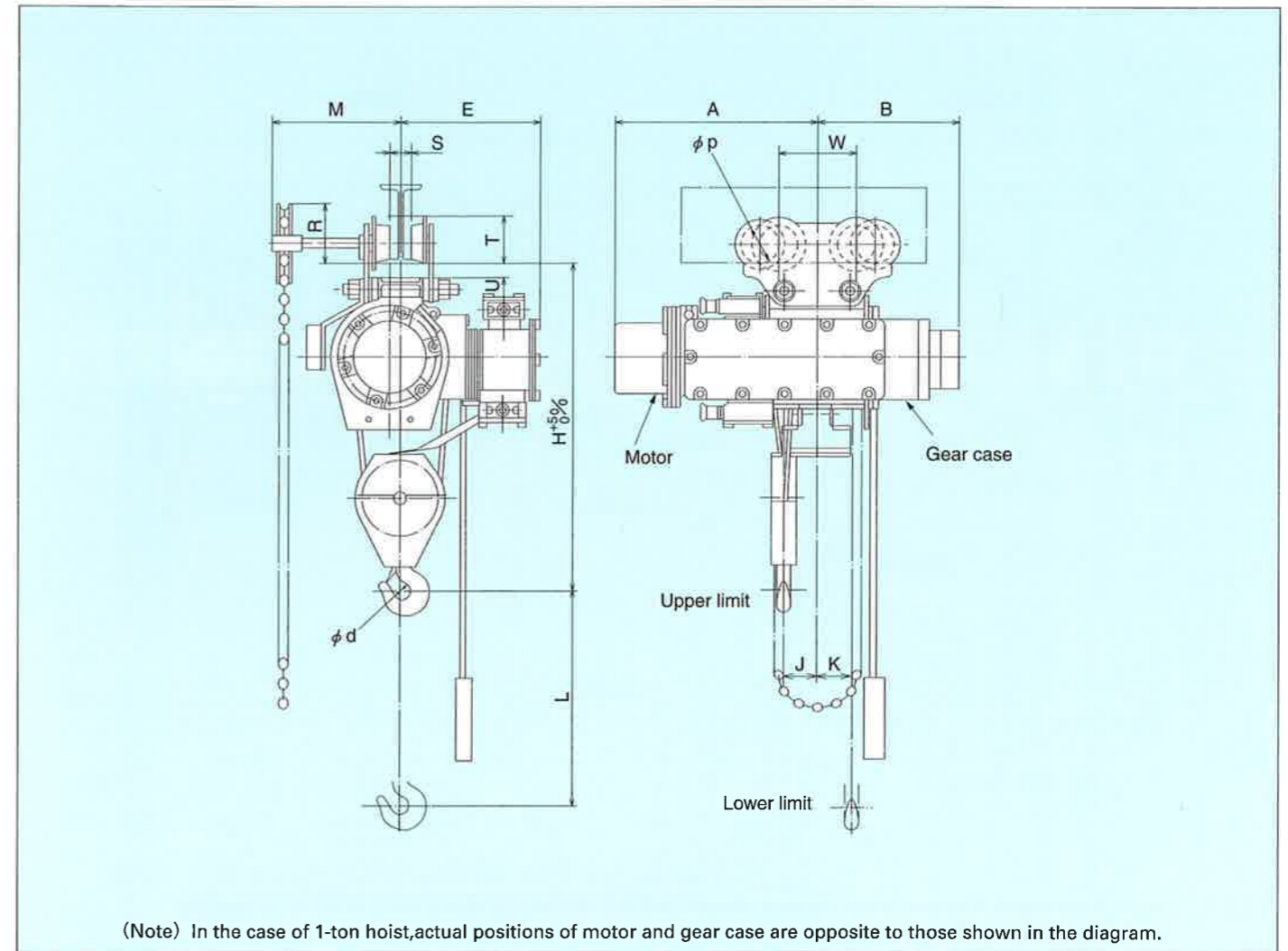

Capacity (ton)		1		2		3										
Type	1M-C ₆₅ -XX	1HM-C ₆₅ -XX	2M-C ₇₅ -XX	2HM-C ₇₅ -XX	3M-C ₆₅ -XX	3HM-C ₆₅ -XX										
Approx. dimensions (mm)	L	6,000	12,000	6,000	12,000	6,000	12,000									
	H	775		985		1,150										
	A	570	740	625	660	690	730									
	B	475	510	435	615	475	660									
	E	430		490		530										
	J	85	115	75	100	80	110									
	K	20	90	30	110	35	120									
	φd	45		56		71										
	φp	85		110		110										
	W	189/350		231/350		231/350										
Min. curve radius (m)	4.0		4.0		4.0											
Dimensions of I-beam (mm)	M	R	S	T	U	M	R	S	T	U	M	R	S	T	U	
200×100×7	350	134	51	121	32	366	188	33	150	40	—	—	—	—	—	
250×125×7.5	363	137	76	124	29	379	200	58	153	37	379	200	58	153	37	
300×150×11.5	376	147	101	134	19	392	210	83	163	27	392	210	83	163	27	
450×175×11	—	—	—	—	—	—	—	—	—	—	405	208	108	161	29	
Approx. weight (kg)	345		360		435		455		540		580					

(Note) Unless otherwise specified, trolley is being assembled so as to meet smudged I-beam.

Standard Head room Type Stationary Hoist

Dimensional diagram

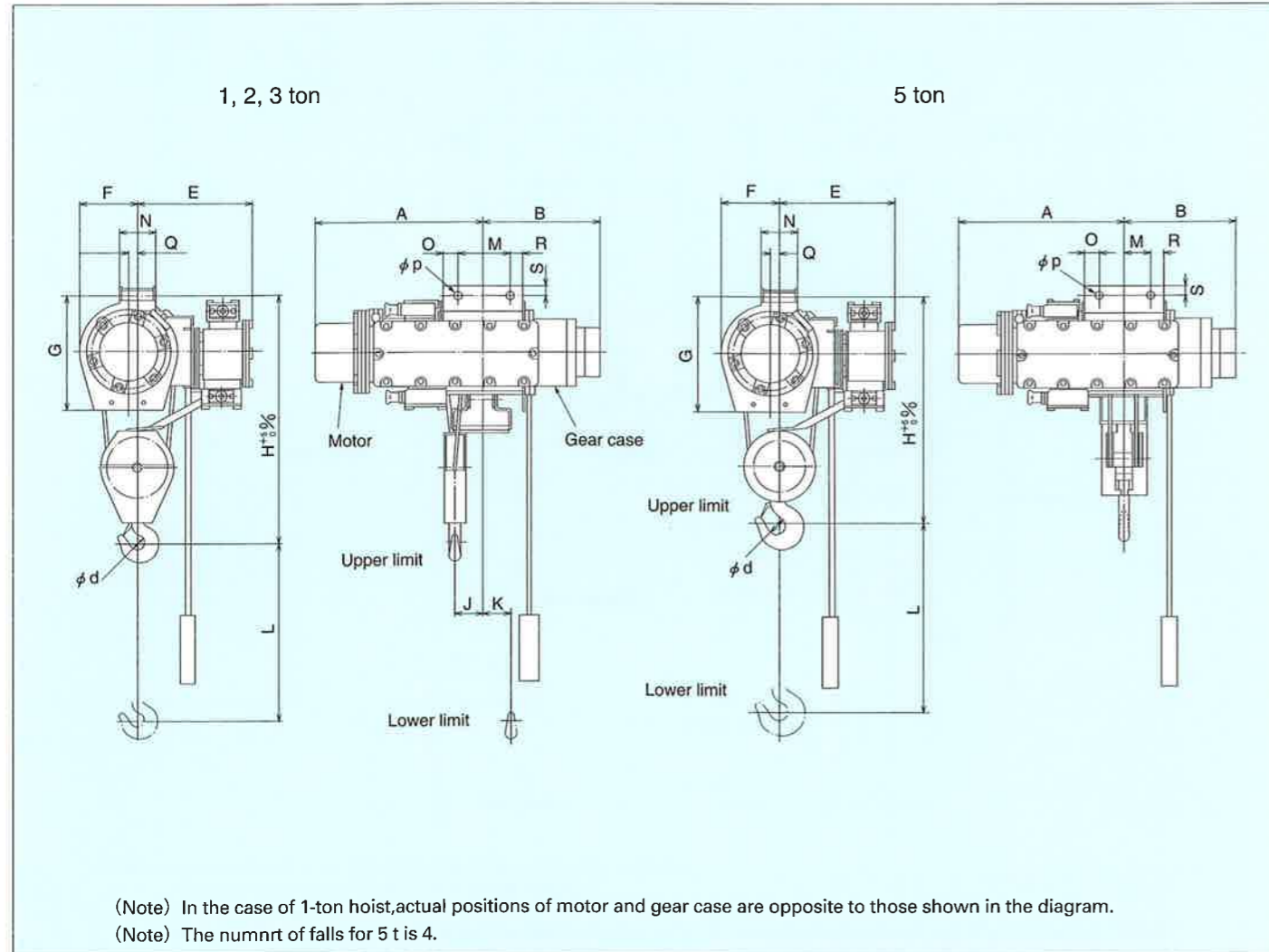

Capacity (ton)		1		2		3		5	
Type		1M ₆ -XX	1HM ₆ -XX	2M ₇ -XX	2HM ₇ -XX	3M ₆ -XX	3HM ₆ -XX	5M ₅ -XX	5HM ₅ -XX
Approx. dimensions (mm)	L	6,000	12,000	6,000	12,000	6,000	12,000	8,000	12,000
	H	710		910		1,050		1,110	
	A	570	740	625	660	690	730	890	1,000
	B	475	510	435	615	475	660	690	800
	E	430		490		530		540	
	F	255		220		245		305	
	G	390		500		555		590	
	J	85	115	75	100	80	110	—	—
	K	20	90	30	110	35	120	—	—
	M	200		200		200		270	
	N	139		139		164		189	
	O	47	80	56	91	65	106	198	310
	Q	32.5		35.5		41.5		52.5	
	R	47	217	58	237	79	262	198	310
	S	40		35		35		50	
	φ	26		36		36		46	
	φd	45		56		71		90	
Approx. weight (kg)		235	250	320	345	425	465	625	685

Low-Head-room Type Hoist with Motorized Trolley

Dimensional diagram

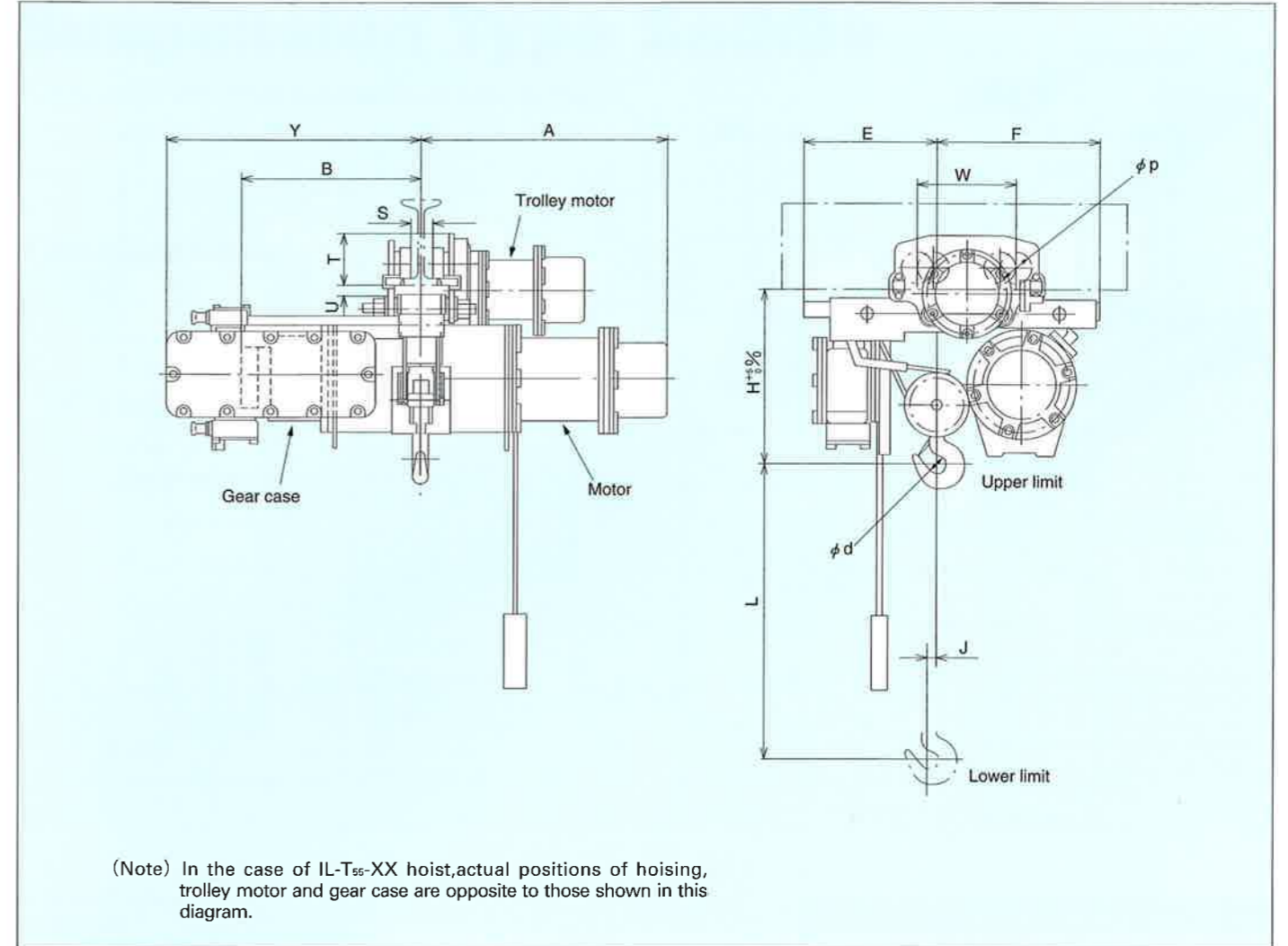

Capacity (ton)		1		2		3		5		
Type		1L-T ₅₅ -XX	1HL-T ₅₅ -XX	2L-T ₅₅ -XX	2HL-T ₅₅ -XX	3L-T ₅₅ -XX	3HL-T ₅₅ -XX	5L-T ₅₅ -XX	5HL-T ₅₅ -XX	
Approx. dimensions (mm)	L	6,000	12,000	6,000	12,000	6,000	12,000	6,000	11,000	
	H	425	450	515	520	600	650	810		
	A	690	710	730	810	830	880	890	1,000	
	B	475	560	540	635	600	700	690	800	
	E	370	400	435	380	470	480	610		
	F	360	465	480	565	575	660	680		
	J	31	30	42	34	46	50	35		
	Y	760		770		760		820	845	
	φd	45		56		71		90		
	φp	96		96		128		156/140 Drive side/Following side		
	W	200/290		200/290		230/310	230/410	250/330		
Min. curve radius (m)		1.8		2.0		2.5	3.5	3.5		
Dimensions of I-beam (mm)		S	T	U	S	T	U	S	T	U
200×100×7		42	148	52	42	148	32	—	—	—
250×125×7.5		67	151	49	67	151	29	52	177	28
300×150×11.5		92	160	40	92	160	20	77	187	18
450×175×11		—	—	—	—	—	—	102	185	20
Approx. weight (kg)		340	420	435	530	600	800	905	965	

(Note) Unless otherwise specified, trolley is being assembled so as to meet smudged I-beam.

Double-Rail Type

Hoist with Motorized Trolley

Dimensional diagram

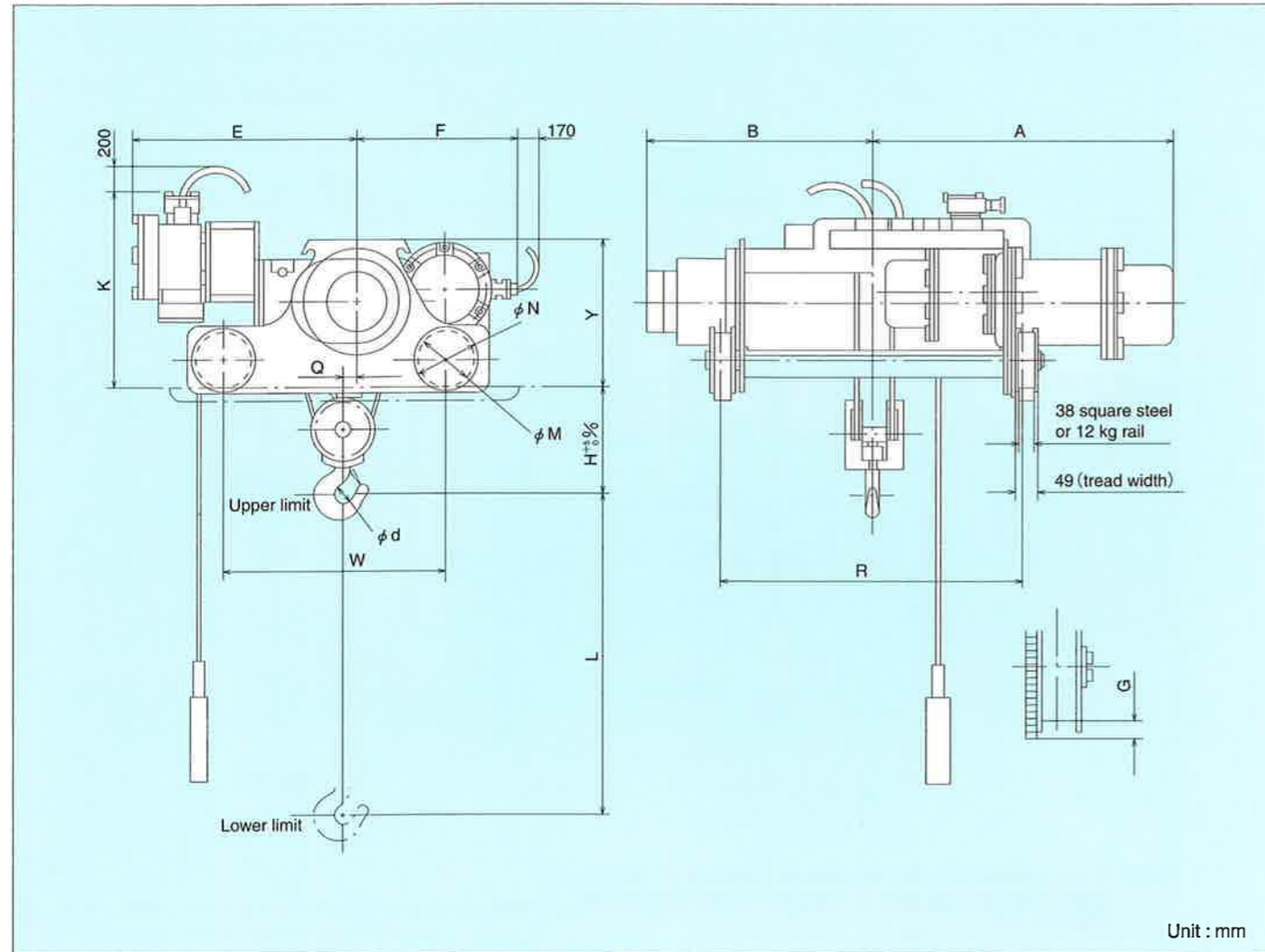

Capacity (ton)	2		3		5	
Type	2HD-T ₅₅ -XX	3D-T ₅₅ -XX	3HD-T ₅₅ -XX	5D-T ₅₅ -XX	5HD-T ₅₅ -XX	
	12,000	6,000	12,000	8,000	12,000	
Approx. dimensions (mm)	L		360		560	
	H	310				
	A	870	800	960	890	1,000
	B	675	570	730	690	800
	E	685		715		735
	F	530		550		600
	G	26		26		26
	K	560		565		715
	Q	40		51		55
	R	900	650	950	900	1,150
	W	650		650		850
	Y	430		480		500
	phi d	56		71		90
phi M	160		160		160	
phi N	190		190		190	
Rail	12kg rail or 38 square steel					
Tread (mm)	49					
Approx. weight (kg)	510	580	680	830	900	

Explosion-Proof Crane Saddle

Suspension Type Saddle

Highly stable type owing to adoption of a sturdy frame.

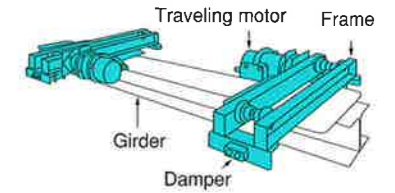

Dimensional diagram

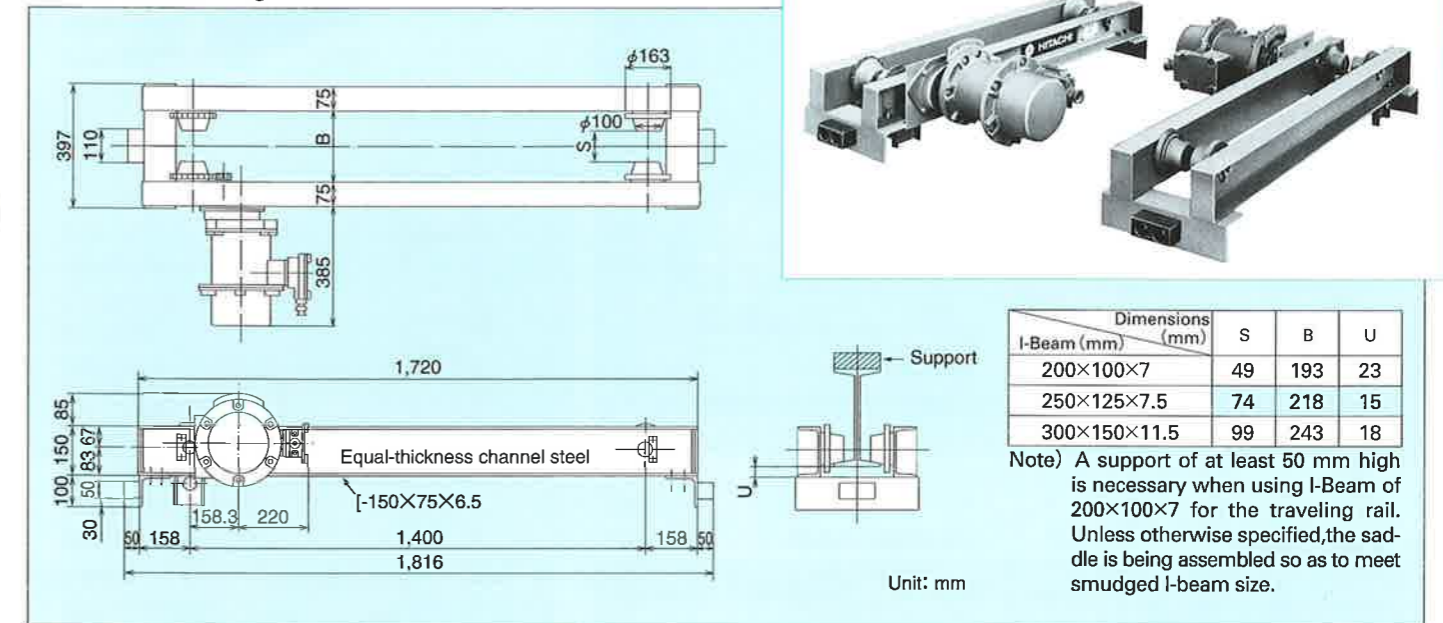

Specifications

Specifications	Type	SL ₆ -28-XX
Maximum span (m)		12
Maximum wheel load t (with 2 wheels)		2.8
Traveling speed (m/min, 50/60Hz)		21/25
Motor (kW, 50/60Hz)		0.30/0.36×units with brake
Ratings	Duty rating	25
	Number of starting	250
Power source (3-phase)		380V, 400V, 415V 50Hz 400V, 440V 60Hz
Applicable traveling I-beam		Refer to the Dimensional diagram. (The dimensions at the time of shipment are the same as those marked with <input type="checkbox"/> . Adjust them when assembling.)
Approx. weight		130×2

Note) 1. The saddle is coated for rust prevention only.

Use 3PNCT for the saddle motor wire.

The standard size of cable is 4C×2mm² (finished outer diameter phi 17.2). Specify separately if the cable size is different.

A control box for the saddle is available on order.

Saddle selection

The Hitachi suspension type crane saddle uses I-beam for the girder as the standard.

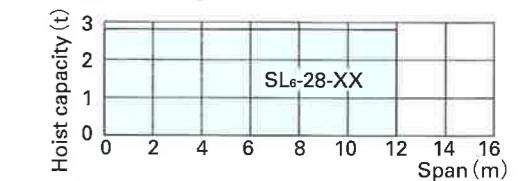

Note) The capacity shown in the drawing at left shows approximate capacity to the maximum span. In the actual selection, the wheel load including the girder must be calculated.

I-beam for girder (mm)	Span length (mm)	SL ₆ -28-XX		
		200×100	250×125	300×150
5		0.4	0.5	0.5
6		0.4	0.5	0.5
7		0.4	0.5	0.6
8		0.6	0.6	0.6
9		0.6	0.6	0.6
10		0.6	0.6	0.6
12		0.6	0.6	0.6

Note) The I-beam used as a girder must be reinforced depending on the span length. The values shown above are tolerance values of overhang at a side.

Top-Run Type Saddle

Top-Run type saddle of wide application range.
This saddle is used for hoist crane in many cases.

Dimensional diagram

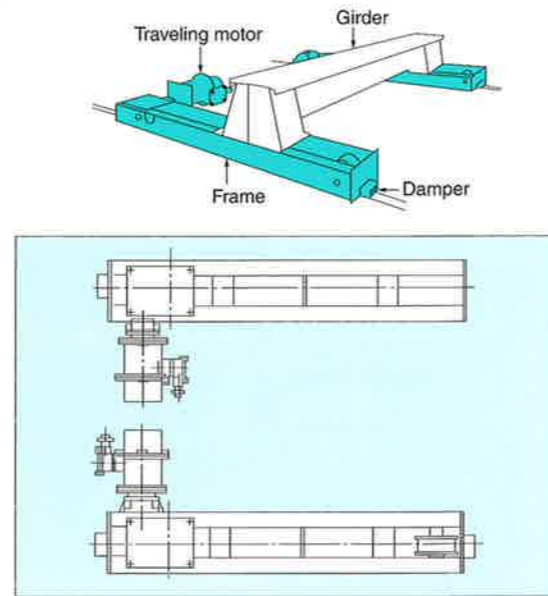
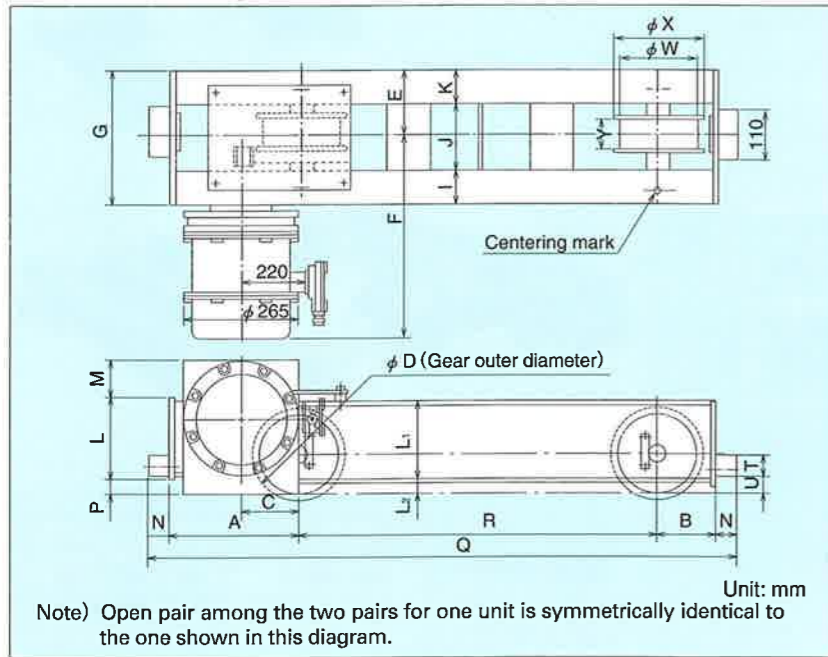

Specifications

Specifications	Type	TH ₅ -10-XX	TH ₅ -28-XX	TH ₅ -30-XX	TH ₅ -56-XX
Maximum span (m)		10	12	16	18
Maximum wheel load (t)		1.0	2.8	3.0	5.6 (4.0) *
Traveling speed (m/min, 50/60Hz)		21/25			
Motor output (kW, 50/60Hz)		0.30/0.36×2 units with brake			0.70/0.84×2 units with brake
Ratings	Duty rating %	25			
	Number of starting (times/hr)	250			
Power source (3-phase)		200V, 380V, 400V, 415V 50Hz		200V, 220V, 400V, 440V 60Hz	
Traveling rail (kg)		12,15	15,22	15,22	30
Approx. weight (kg)		115×2	145×2	220×2	325×2

- Note) 1. The saddle is coated for rust prevention only.
2. TH₅-56-XX is for double rails.
3. (4.0) * shows the maximum wheel weight when using a mono-rail.

Saddle selection

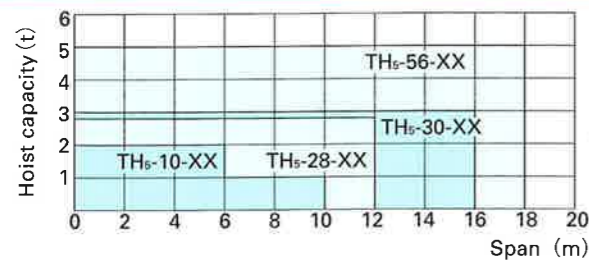

Note) The capacity shown above shows the approximate weight to the maximum span. In the actual selection, the wheel load including the girder must be calculated.

Table of dimensions

(Unit: mm)

Type	TH ₅ -10-XX	TH ₅ -28-XX	TH ₅ -30-XX	TH ₅ -56-XX
A	120	150	300	350
B	120	150	135	175
C	105	135	134	170
φ D	178	229	229	299.6
E	109	135	135	145
F	525	565	565	585
G	245	305	295	322
I	65	75	75	80
J	105	145	145	162
K	65	75	75	80
L	141	166	196	220
L ₁	125	150	180	200
L ₂	20	30	30	40
N	50	50	50	70
M	140	120	95	85
P	12	22	22	30
Q	1,340	1,800	2,535	2,965
R	1,000	1,400	2,000	2,300
T	50	50	50	60
U	25	35	35	60
Y	56	63	63	70
φ W	125	180	180	250
φ X	155	210	210	282

- Note) 1. The motor is installed in the right hand side of the wheel on TH₅-10-XX and TH₅-28-XX.
2. One pair among the two pairs for one unit is symmetrically identical to the one shown in this diagram.
3. Equal-thickness channel steel is used for TH₅-10-XX and TH₅-28-XX.

Table of Explosion and Ignition Rating for Explosive Gases

Item	Explosion rating	Ignition rating	Item	Explosion rating	Ignition rating
Ethyl acrylate	1	G2	Cyclohexane	1	G3
Methyl acrylate	1	G2	Ethyl bromide	1	G1
Acrylonitrile	1	G1	Di-isopropyl ether	1	G2
Ethyl nitrite	1	G6	1,4-dioxane	1	G2
Acetylacetone	1	G2	1,2-dichloroethane	1	G2
Acetylene	3	G2	1,1-dichloroethylene	1	G1
Acetaldehyde	1	G4	(trans-) 1,2-dichloroethylene	2	G1
Acetonitrile	1	G1	Dibutyl ether	1	G4
Acetone	1	G1	Dimethyl ether	1	G3
Ammonia	1	G1	Ethyl nitrate	3	G6
Isooctane	1	G2	Hydrogen	3	G1
Isobutanol	1	G2	Styrene	1	G1
Isobutyl methyl ketone	1	G1	Thiophene	1	G2
Isoprene	2	G3	Tetrahydrofuran	1	G3
Isopentane	1	G2	Decane	1	G3
Carbon monoxide	1	G1	1,2,4-trimethylbenzene	1	G1
Ethanol	1	G2	Toluene	1	G1
Ethane	1	G1	Carbon dioxide	3	G5
(Di) ethyl ether	1	G4	1,3-butadiene	2	G2
Ethyl methyl ketone	1	G1	Furan	1	G2
Ethylene	2	G2	1-butanol	1	G2
Ethylene oxide	2	G2	Butane	1	G2
Epichlorohydrin	1	G2	Butyl aldehyde	1	G3
Isopropyl chloride	1	G1	2-propanol	1	G2
Vinyl chloride	1	G2	Propane	1	G1
Butyl chloride	1	G3	Propylene	1	G2
Octane	1	G3	Propylene oxide	2	G2
o-Xylene	1	G1	1-hexanol	1	G3
m-Xylene	1	G1	Hexane	1	G3
p-Xylene	1	G1	Heptane	1	G3
Chlorobenzene	1	G1	Zenzene	1	G1
Acetic acid	1	G1	Benzotrifluoride	1	G1
Isopentyl acetate	1	G2	1-pentanol	1	G3
Ethyl acetate	1	G1	Pentane	1	G3
Vinyl acetate	1	G2	Acetic anhydride	1	G2
Butyl acetate	1	G2	Methyl methacrylate	1	G2
Propyl acetate	1	G2	Methanol	1	G1
Pentyl acetate	1	G2	Methane	1	G1
Methyl acetate	1	G1	2-methylhexane	1	G3
Hydrogen cyanide	1	G1	3-methylhexane	1	G3
Cyclohexanone	1	G2	Hydrogen sulfide	2	G3
			Gasoline	1	G3
			Water gas	3	G1
			Coal gas	2	G1

(Except from Explosion-proof Guideline for Electrical Equipment in Factories, provided by the Technical Institution of Industrial Safety, Japan)

WARNING

The equipment shown in this catalogue is intended for industrial use only and should not be used to lift, support, or otherwise transport human cargo.

Specifications in this catalog are subject to change with or without notice, as Hitachi continues to develop the latest technologies and products for its customers.

 **Hitachi Industrial Equipment Systems Co., Ltd.**

For further information, please contact your nearest sales representative.